ABSTRACT

In this paper, a hybrid energy storage system is devised using Electro-Chemical Double Layer Capacitors (Ultra- Capacitors) and batteries. The objective of the work is to design and analyze a hybrid energy storage system in order to achieve optimal power flow from sources considering load demand. Electro-Chemical Double Layer Capacitors are suited to supplying loads of short duration and high power, while batteries are better suited to supplying loads of long duration and low power. The loads on a domestic system are a combination of long duration low power demand and short duration high power demand. The relative strengths of batteries and super-capacitors lend themselves to supplying the two components of load. This work seeks to quantify what gains may be made by combining lead acid batteries and ultra-capacitors in a hybrid energy storage system and dispatching the two components to supply the load components suited to their strengths.

KEYWORDS: Batteries, hybrid energy storage, photovoltaic system, ultra-capacitors.

I. INTRODUCTION

Man has devised various ways to generate, distribute and use energy. However, it is well recognized that our weakest link to future is energy storage. Methods for storage of electrical energy by use of flywheels and compressed air are still to mature. Electrochemical materials in rechargeable batteries and ultra capacitors provide a convenient and efficient medium for storage of energy on a small-to-medium scale. Because of their small size, modular design, silent operation, high efficiency, and instantaneous response, batteries and ultra capacitors are convenient power packs. Apart from providing energy on demand as for portable gadgets, remote area lighting and uninterruptible power supplies, these electrochemical devices can help buffer load fluctuations as well as meet power demands of emerging technologies such as in electric and hybrid electric vehicles, and satellites. The earliest stationary power application was in telephony, which then expanded into other areas such as railway signal system, lighting in operation theatres, communication gadgets, and miner's lamps. Today batteries are part of the uninterruptible power supply units of establishments, large and small, as well as in ships and submarines, computing facilities and nuclear control stations. They are also ideal for stand-alone applications, away from the main grid. In such cases as for remote lighting as is being exploited in the national literary mission, batteries can be coupled with a primary renewable source (wind energy, solar energy, biomass, etc.) as may suit the end-use locality.

Electrochemical batteries are used as storage but to reach autonomy, it is often necessary to oversize them, and this increases the cost and the size of the over-all system.[1][2] Almost all the existing solar energy harnessing projects using PV(Photo Voltaic Cell Arrays) panels are designed to meet the constant or nearly constant loads (load of unvarying nature). The operation of these systems under varying load environment has proved to be unsatisfactory (at peak loads the system has to draw power from the grid and when under loaded the system works inefficiently). Under such varying load circumstances the Photovoltaic System with a Battery and Ultra-capacitor Energy Storage Hybrid System has proved to be highly beneficial with a view that the ultra-capacitor has a higher power density and can provide a large amount of power over a short period of time. [3][4][5] Batteries and ultra-capacitors complement each other in terms of their power and energy densities. In the hybrid

configuration the batteries supply the load demand energy; while the ultra-capacitor bank supplies the instantaneous power requirements.

II. SUPER CAPACITOR MODULE

Ultra or Super-capacitors are efficient energy storage devices that have been developed in recent years into products that can be used in electrical power applications for energy storage. Renewable energy systems by their intermittent nature are dependent on energy storage and/or traditional fossil fuel generation to maintain reliable electricity supply. Super-capacitors are suited to supplying loads of short duration and high power, while batteries are better suited to supplying loads of long duration and low power. The loads on the existing system are a combination of long duration low power demand and short duration high power spikes in demand. The relative strengths of batteries and super-capacitors lend themselves to supplying the two components of load. This project seeks to quantify what gains may be made by combining lead acid batteries and super-capacitors in a hybrid energy storage system and dispatching the two components to supply the load components suited to their strengths. [14][15]

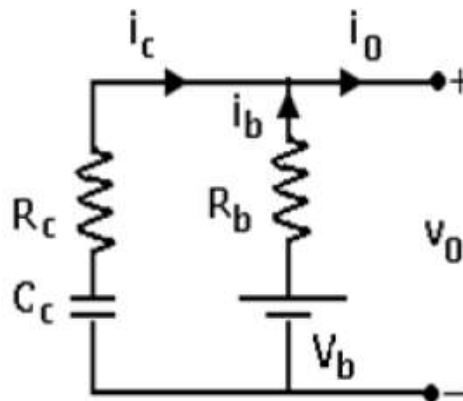

Fig.1 Equivalent Circuit

From the equivalent circuit,

Battery=Ideal Voltage Source, V_b in series with internal resistance, R_b
Ultra-Capacitor= Capacitor, C_c in series with an equivalent resistance, R_c

Battery Current,

$$i_b(t) = 1/R_b[V_b - V_o(t)]$$

Ultra Capacitor Current

$$i_c(t) = [i_o(t) - i_b(t)]$$

Ultra-capacitors are available in a full range of sizes. This enables utilization of ultra-capacitors in a variety of industries for many power requirement needs. These applications span from milliamps current or milli-watt power to several hundred amps current or several hundred kilowatts power needs.

Consumer – Digital cameras, lap top, computers, PDA's, GPS, hand held devices, toys, flashlights, solar accent lighting, and restaurant paging devices.[16]

Traction – Diesel engine starting, train tilting, security door opening, tram power supply, voltage drop compensation.

Automotive – 42 V vehicle supply networks, power steering, electromagnetic valve controls, starter generators, electrical door opening, regenerative braking, hybrid electric drive, active seat belt restraints.[17]

Industrial – uninterrupted power supply (UPS), wind mill pitch systems, power transient buffering, automated meter reading (AMR),[18] elevator micro-controller power backup, security doors, forklifts, cranes, and telecommunications.

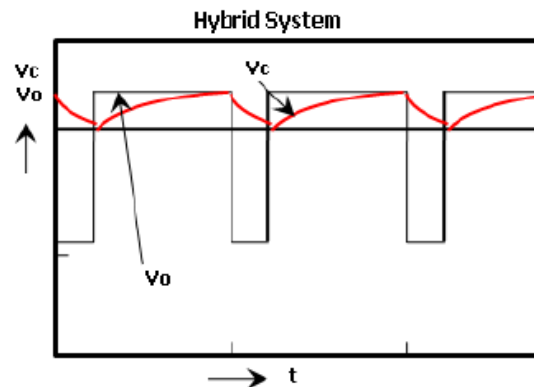

Fig.2 voltage of Hybrid system showing reduction in voltage drop

III. PERFORMANCE PARAMETER

1. Temperature effects and performance changes over time

The performance of ultra-capacitors is very stable over a wide operating temperature due to the chemistry and physical make up of the products. An advantage of the ultra-capacitors' organic based electrolyte is its low freezing point. This enables the ultra-capacitors to be utilized over a wide range of temperatures, with relatively unaffected performance.

2. Lifetime

Ultra-capacitor life is predominantly affected by a combination of operating voltage and operating temperature. The ultra-capacitor has an unlimited shelf life when stored in a discharged state. When referring to ultra-capacitor life the data sheets reflect the change in performance, typically decrease in capacitance and increase in resistance. The ultra-capacitor does not experience a true end of life rather the performance continually degrades over the life of the use of the product.

The typical degradation behavior of the ultra-capacitor resembles that of an exponential decay. The majority of the performance change occurs during the initial use of the ultra-capacitor and this performance change then levels off over time. The most dramatic effect of the life degradation is on the internal resistance of the device. In many applications, such as UPS, the ultra-capacitors (UC) will be maintained at working voltage until needed. To give one example, a 15% reduction in rated capacitance and a 40% increase in rated resistance may occur for an ultra-capacitor held at 2.5 V after 88,000 hrs at 25°C. The influence of temperature has a doubling effect for every 10°C, this behavior of UC can be used to predict the expected performance change for a variety of conditions.

3. Cycling

From cycle testing performed on ELDCs, under typical conditions the product is expected to provide in excess of 1 million duty cycles with an approximate 20% reduction in rated capacitance.

4. Frequency response

Ultra-capacitors have a typical time constant of approximately one second. One time constant reflects the time necessary to charge a capacitor 63.2% of full charge or discharge to 36.8% of full charge.

The time constant of an ultra-capacitor is much higher than that of an electrolytic capacitor. Therefore, it is not possible to expose ultra-capacitors to a continuous ripple current as overheating may result. The ultra-capacitor can respond to short pulse power demands, but due to the time constant the efficiency or available energy is reduced. [19]

5. Voltage

Ultra-capacitors are capable of operating between their rated voltage and zero volts. Occasional spikes above the rated voltage will not immediately affect the capacitor. Depending on the frequency and duration of voltage spikes the life will be reduced. Efficient utilization of the available energy and power storage is achieved with the widest operating voltage range used. Most electronics have a minimum voltage threshold for utilization,

limiting the effective utilization voltage of the capacitor although there is no limitation in the capacitor itself. Since the energy in the capacitor is proportional to the voltage squared according to $E = \frac{1}{2} CV^2$. It is possible to utilize approximately 75% of the available energy if the application utilizes from the rated voltage to $\frac{1}{2}$ rated voltage of the capacitor.

6. Polarity

Unlike many batteries the anode and cathode of an ultra-capacitor are comprised of the same material. If the positive and negative terminal and casing are also comprised of similar materials, then theoretically the ultra-capacitor has no true polarity. For manufacturing and consistency purposes the terminals are marked with polarity. It is recommended practice to maintain the polarity although catastrophic failure will not occur if the ultra-capacitor is reversed charged some reason. If the ultra-capacitor has been conditioned for charge in a certain direction and then is changed, the life can be reduced due to this conditioning. Due to the corrosion potential it is required to maintain the polarity indicated on the UC, and reverse polarity will cause accelerated life reduction.

7. Charging

Since the energy storage mechanism of the ultra-capacitor is not a chemical reaction, charging /discharging of the ultra-capacitors can occur at the same rate. Therefore, the rated current for the ultra-capacitor applies for both charge and discharge. The efficiency of charge and discharge are in practical terms the same. A variety of methods are possible for charging of the ultra-capacitors. This may be either through constant current or constant power charging via a dc source or through ac charging methods.

8. Series connection and balancing

Since the individual ultra-capacitor cell voltage is relatively limited compared to the majority of application requirements, it is necessary to series connect the ultra-capacitors to achieve the voltage required. Because each ultra-capacitor will have a slight tolerance in capacitance and resistance it is necessary to balance, or prevent, individual ultra-capacitors from exceeding its rated voltage. Balancing can be achieved through two different methods, active balancing or passive balancing.

Active balancing schemes are varied. This methodology always attempts to balance two adjoining ultra-capacitors based on the voltage mismatch between the two. The maximum current during balancing varies by capacitor to capacitor.

Passive balancing implies no variation in the voltage regulation as a function of the ultra-capacitor condition. The most typical method of passive balancing utilizes resistors in parallel with the ultra-capacitors.

A variety of interconnection methods are practiced. They range from bus bar interconnecting to soldering. In general the larger the cell capacitance the more critical the cell interconnection becomes. The larger capacitance devices have internal resistances on the order of a few hundred micro-ohms. A poor interconnection can have more resistance than the internal resistance of the device itself. Larger devices will generally be required to carry larger currents, thus necessitating reliable interconnects.

9. Efficiency

Unlike batteries, the ultra-capacitor has the same efficiency during charge or discharge. This enables the ultra-capacitor to be recharged quickly without current limiting as long as the current is within the rated current for the device.

The only efficiency losses associated with ultra-capacitors are due to internal resistance of the device resulting in IR drop during cycling. For most uses the ultra-capacitor efficiency is in excess of 98%. For high current or power pulsation the efficiency is reduced. Typical efficiency under high current pulses is still greater than 90%.

10. Thermal Properties

For minimum performance influence over the life of the application it is necessary to maintain the ultra-capacitor core temperature within the rated temperature range of the device. The lower the temperature is maintained the better for life considerations. For this reason, since all current passes through the capacitor terminals, cooling at the capacitor ends or terminals is the most efficient means for cooling of the capacitor.

Depending on the duty cycle of the application cooling can be accomplished via heat sinks (conduction), air flow (convection) or a combination of the two. Consideration should be made for the duty cycle and resulting capacitor temperature as well as the anticipated ambient temperature the device will be operating under. The combination of the two should not exceed the operating temperature for the ultra-capacitor.

IV. CONCLUSION

From the discussion above it could be concluded that adding ultra-capacitors decreases the losses in batteries. This advantage is all the more important at low temperatures. It is thus possible to reduce the dimensioning of the batteries, especially when the influence of the temperature is taken into account (batteries having poor yield at low temperature). Another effect not shown here is fact that ultra-capacitors should improve the life-cycles and sustainability of batteries by limiting their discharge current. However, the fact that ultra-capacitors cannot store a lot of energy means that they cannot be used without batteries. Finally, a more effective charge and discharge protocol not based only on voltages but also on the storage state of charge should improve the efficiency of the whole system

V. REFERENCES

- [1] C. Chan, "The state of the art of electric and hybrid vehicles," Proc. representative driving patterns. Researchers in [25] use GPS of the IEEE, vol. 90, pp. 247-275, Feb. 2002.
- [2] "FreedomCAR Battery Test Manual For Power-Assist Hybrid Electric system data to approximate the driving schedule. Assuming Vehicles," June 2006,
- [3] A. Schneuwly, "Charge Ahead, Ultra-capacitor Technology and Applications", The IEE Power Engineer, vol. 19, Issue 1, pp 34-37, Feb-March 2005
- [4] A.F. Burke, "Prospects for ultra-capacitors in electric and hybrids," 11th Annual Battery Conference on applications and Advances, pp. 183-188, Long Beach, January 1996
- [5] M.-Y. Ayad, S. Rael, S. Pierfederici, B. Davat, "Supercapacitors for embarked systems as a storage energy device solution," ESSCAP'04, Belfort, November 2004
- [6] N. Femia, G. Petrone, G. Spagnuolo, M. Vitelli, "Optimizing sampling rate of P&O MPPT technique," PESC 04. 2004 IEEE 35th Annual Volume 3, 20-25 June 2004, pp. 1945-1949 vol.9
- [7] R. Caceres, I. Barbi, "A Boost DC-AC Converter: Analysis, Design, and Experimentation," IEEE Transactions on Power Electronics, vol.14 no. 1, January 1999
- [8] G. Walker, P. Sernia, "Cascaded DC-DC converter connection of photovoltaic modules," IEEE Transactions on Power Electronics, vol.19, no. 4, July 2004
- [9] A. Neusser, P. Boulanger, H. Colin, D. Lafore, P. Malbranche, P. Mestre, "A New Modular Architecture Concept for PV Systems: simulations and comparative studies", 17th European Photovoltaic Solar Energy Conference and Exhibition, 22-26 October 2001, Munich, Germany
- [10] R. Bonert, L. Zubieta, "Characterization of Double-Layer Capacitors for Power Electronics Applications", IEEE TRANSACTIONS ON INDUSTRY APPLICATIONS, VOL. 36, NO. 1, January/February 2000
- [11] Burke, A. (2009) "Ultracapacitor Technologies and Application in Hybrid and Electric Vehicles," International Journal of Energy Research.
- [12] Stienecker, A. W., T. Stuart, and C. Ashtiani (2006) "An ultracapacitor circuit for reducing sulfation in lead acid batteries for Mild Hybrid Electric Vehicles," Journal of Power Sources, 156, pp. 755-762.
- [13] Eichenberg, D. J., J. S. Kolacz, and P. F. Tavernelli (2001) "Baseline Testing of the Ultracapacitor Enhanced Photovoltaic Power Station," Tech. rep., National Aeronautics and Space Administration Glenn Research Center.
- [14] Schneuwly, A. "Ultracapacitors improve reliability for wind turbine pitch systems," White paper-Maxwell Technologies.
- [15] Kotz, R. and M. Carlen (1999) "Principles and applications of electrochemical capacitors," Electrochimical Act, 45, pp. 2483-2498.
- [16] Shah, V., J. A. Joshi, R. Maheshwari, and R. Roy (2008) "Review of Ultracapacitor Technology and its.